

5000i HD

Large, heavy duty fume extraction unit

PUREX
CLEAN AIR FOR EVERYONE

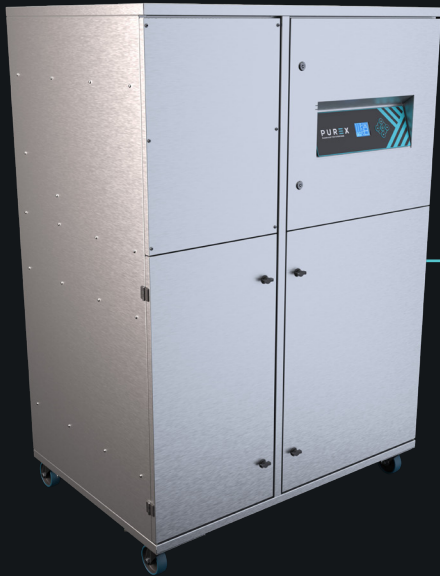

Description & features

- Clear & informative graphic display
- Highest grade HEPA and carbon technology
- Automatic electronic flow control - maintains a constant extraction rate even as the filter blocks
- Gas and particle sensors to warn the operator
- Larger filter capacity for high dust applications

Filters



Main Filter Code

110633

Description

HEPA



Main Filter Code

110627

Description

Chemical



Pre-Filter Code

200600

Description

F8 Pleat Pack



Pre-Filter Code

200044

Description

G3 Pad

Specifications

Voltage	3 phase supply	
	220v	400v
Part Number	OLX5575D	OLX5570D
Wattage	7.5kW	
Frequency	50Hz / 60Hz	
Cabinet Height	1804mm	
Cabinet Width	1250mm	
Cabinet Depth	892mm	
Cabinet Weight	400kg	
Sound Level	<60dBa	

Machine supplied with

• 2 x Main Filter • 3 x Pre-filter • 1 x 4.5m x Fixed Power Cable (No Plug) • 1 x Manual

Find out more: W purex.co.uk | [T +44 \(0\)1405 746030](tel:+44(0)1405746030) | [E purex@purex.co.uk](mailto:purex@purex.co.uk)

Registered Office: Purex International LTD, Unit A, Saltgrounds Road, Brough, HU15 1EG, UK

Registered No. 5136616 England | VAT No. GB842 5025 49 | WEEE Producer Registration Number: WEE/CE0067TX

*Goods are subject to change | *Illustrations are 3D created visual representations

5000i HD

Large, heavy duty fume extraction unit

Options

Main filter

Code	Description
110624	Chemical

Connection kits

120296		
Hose End Diameter	Hose Length	Purex Inlet Diameter
200mm	1m	200mm

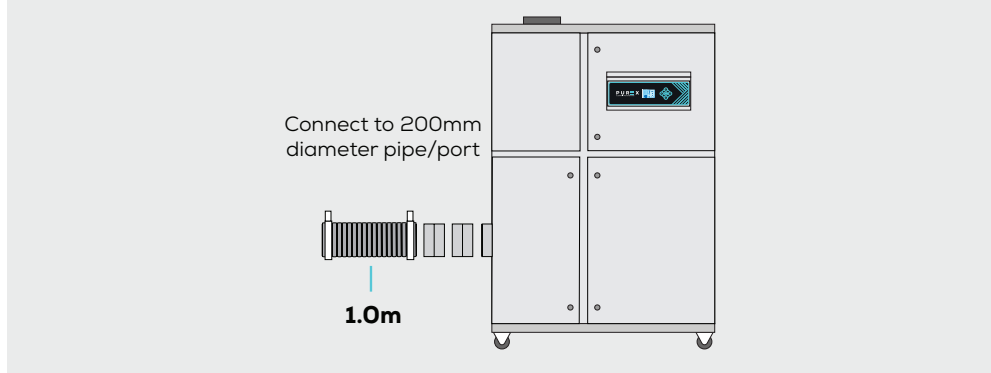

Technical

Rear Inlet

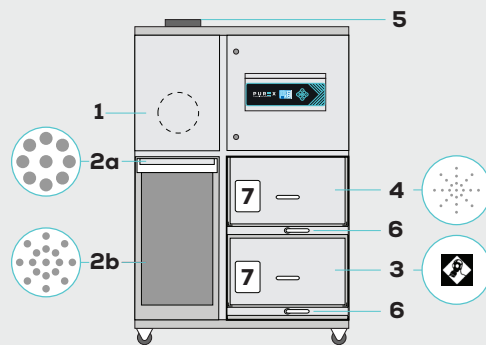

LEGEND:

- 1. Air inlet - 200mm safe seal
- 2a. Pre-filter pad
- 2b. Pre-filter pleated bag
- 2c. Pre-filter labyrinth bag
- 3. Main filter (carbon location)
- 4. Main filter (HEPA location)
- 5. Clean air returned to the workplace
- 6. Filter locking handles
- 7. Filter identification labels

Interfacing

Interfacing can remotely start the Purex machine when the connected machine starts.

Interfacing can also warn the connected machine when the Purex machine is in alarm.



10011010

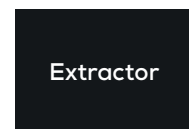

10011010

Take a look through our [Interfacing Guide](#) to see our extensive range of options