

# CONNECTION KITS

Please contact Purex for additional support

**PUREX**  
CLEAN AIR FOR EVERYONE

## 50mm Purex Inlet

**120117**

Diameter of Customers port or pipework	Hose Length	Purex Machine Inlet Diameter
50mm	2.0m	50mm



**2.0m**

1 x 2m x 51mm flexible hose (570249)  
2 x 51mm cuffs (570203)

**120115**

Diameter of Customers port or pipework	Hose Length	Purex Machine Inlet Diameter
50mm	3.0m	50mm



**3.0m**

1 x 3m x 51mm flexihose (570249)  
2 x 51mm flexible hose cuffs (570203)

**100037**

Diameter of Customers port or pipework	Hose Length
50mm	6m (Extension)



**6.0m**

1 x 50mm coupling black (520330)  
1 x 6m x 51mm flexible hose (570249)  
2 x 51mm cuffs (570203)

## 80mm Purex Inlet

**100119**

Diameter of Customers port or pipework	Purex Machine Inlet Diameter
9mm	80mm



**YOUR PROCESS** ← —→ **MACHINE**

1 x 32mm straight pipe connector (500060)  
1 x 32mm pipe plug access (500120)  
1 x aluminium reducer 80mm - 34mm (550283)  
1 x 12mm Adaptor hose (580035)

**100170**

Diameter of Customers port or pipework	Hose Length	Purex Machine Inlet Diameter
32mm	1.5m	80mm



**YOUR PROCESS** ← —→ **MACHINE**

**1.5m**

2 x half straight connector (500061)  
1 x aluminium reducer 80mm - 34mm (550283)  
1 x 1.5m x 41mm flexible hose (570040)  
2 x 35mm to 50mm hose clips (580620)

**100026**

Diameter of Customers port or pipework	Hose Length	Purex Machine Inlet Diameter
50mm	3.0m	80mm



**YOUR PROCESS** ← —→ **MACHINE**

**3.0m**

1 x earth strap 6mm (105054)  
1 x 80mm to 51 reducer (550287)  
1 x 3m x 50mm antistatic hose (570042)  
2 x 51mm antistatic cuffs (570211)  
1 x Pan head screw (700316)  
1 x M4 shakeproof washer (730310)

**STD: 100043 | PVC: 100043C**

Diameter of Customers port or pipework	Hose Length	Purex Machine Inlet Diameter
50mm	6.0m	80mm



**YOUR PROCESS** ← —→ **MACHINE**

**6.0m**

1 x 80-51mm reducer (550287)  
1 x 6m x 51mm flexible hose (570249)  
1 x Flexible hose cuff black (570203)  
2 x 51mm PVC cuffs (120113)

**\*Coated reducers suitable for PVC applications (550287C)**

Find out more: [W purex.co.uk](http://W purex.co.uk) | [T +44 \(0\)1405 746030](tel:+44(0)1405746030) | [E purex@purex.co.uk](mailto:purex@purex.co.uk)

Registered Office: Purex International LTD, Unit A, Saltgrounds Road, Brough, HU15 1EG, UK  
Registered No. 5136616 England | VAT No. GB842 5025 49 | WEEE Producer Registration Number: WEE/CE0067TX  
\*Goods are subject to change

# CONNECTION KITS

Please contact Purex for additional support

**PUREX**  
CLEAN AIR FOR EVERYONE

## 100039

Diameter of Customers port or pipework	Hose Length	Purex Machine Inlet Diameter
--	-------------	------------------------------

50mm      6m (Dual Manifold)      80mm

Use along side a 100043 / 100043C

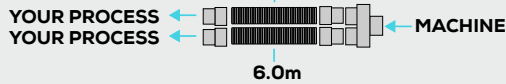

- 1 x dual manifold assembly (120093C)
- 2 x 6m x 51mm flexible hose (570249)
- 2 x 51mm cuffs (570203)

Suitable for PVC applications (120113)

## 100180

Diameter of Customers port or pipework	Hose Length	Purex Machine Inlet Diameter
--	-------------	------------------------------

50mm      2.0m      80mm

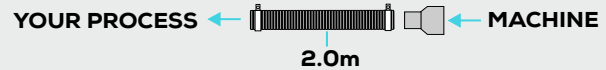

- 1 x 80-53.5mm reducer (550280)
- 1 x 2m x 77mm flexible hose (570050)
- 2 x 45mm to 60mm hose clips (580630)

## STD: 100032 | PVC: 100032C

Diameter of Customers port or pipework	Hose Length	Purex Machine Inlet Diameter
--	-------------	------------------------------

50mm      3.0m      80mm



- 1 x 80mm to 51mm reducer (550287)
- 1 x 51mm cuffs (570203)
- 1 x 3m x 51mm black flexihose (570249)
- 1 x PVC cuffs (120113)

\*Coated reducers suitable for PVC applications (550287C)

## 100019

Diameter of Customers port or pipework	Hose Length	Purex Machine Inlet Diameter
--	-------------	------------------------------

50mm      3.0m      80mm

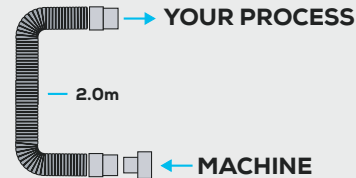

- 1 x 50mm to 57mm connection kit (120117)
- 1 x Reducer aluminium (550287)

## 120285

Diameter of Customers port or pipework	Hose Length	Purex Machine Inlet Diameter
--	-------------	------------------------------

50mm      3.0m      80mm

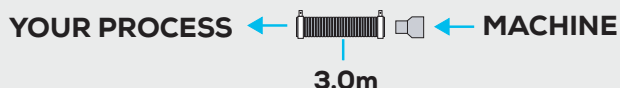

- 1 x Reducer 80mm to 53mm (550280)
- 1 x 3m x 57mm flexible hose (570050)
- 2 x 45mm to 60mm hose clips (580630)

## 100183

Diameter of Customers port or pipework	Hose Length	Purex Machine Inlet Diameter
--	-------------	------------------------------

75mm      1.5m      80mm



- 1x 75mm - 75mm x 1.5m connection kit (100185)
- 1x Clean cab - open hoode 75mm port (840155)

## 100185

Diameter of Customers port or pipework	Hose Length	Purex Machine Inlet Diameter
--	-------------	------------------------------

75mm      1.5m      80mm



- 2 x 85-75mm reducer (840113)
- 1 x 1.5m x 75mm flexible hose (570305)

## 120327

Diameter of Customers port or pipework	Hose Length	Purex Machine Inlet Diameter
--	-------------	------------------------------

76mm      1.0m      80mm

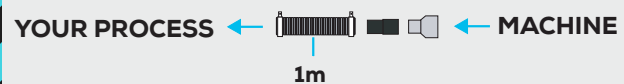

- 1x Aluminium reducer 80mm - 63mm (550293)
- 1 x 1m x 76mm flexihose (570305)
- 1x Hose cuff 63mm (570205)
- 2x Hose clip 70-90 (580650)

Find out more: [W purex.co.uk](http://W purex.co.uk) | [T +44 \(0\)1405 746030](tel:+44(0)1405746030) | [E purex@purex.co.uk](mailto:purex@purex.co.uk)

Registered Office: Purex International LTD, Unit A, Saltgrounds Road, Brough, HU15 1EG, UK

Registered No. 5136616 England | VAT No. GB842 5025 49 | WEEE Producer Registration Number: WEE/CE0067TX

\*Goods are subject to change

# CONNECTION KITS

Please contact Purex for additional support

**PUREX**  
CLEAN AIR FOR EVERYONE

## 120262

Diameter of Customers port or pipework	Hose Length	Purex Machine Inlet Diameter
80mm	2.0m	80mm

YOUR PROCESS ←  ← MACHINE

2m

- 1x 80mm coupling (540025)
- 1x 2m x 80mm flexihose (570053)
- 2x Hose clip 70 - 90mm (580650)

## 120293

Diameter of Customers port or pipework	Hose Length	Purex Machine Inlet Diameter
80mm	1.3m	80mm

YOUR PROCESS ←  ← MACHINE

1.3m

- 1 x 80mm female coupling (540025)
- 2 x 70 - 90mm hose clips (580650)
- 1 x 1.3m x 82mm flexible hose (570053)

## 120350

Diameter of Customers port or pipework	Hose Length	Purex Machine Inlet Diameter
80mm	0.8m	80mm

YOUR PROCESS ←  ← MACHINE

0.8m

- 1 x 0.8m x 84mm flexihose (570053)
- 2x Hose clip 70mm - 90mm (580650)

## 120304

Diameter of Customers port or pipework	Hose Length	Purex Machine Inlet Diameter
80mm	6.0m	80mm

YOUR PROCESS ←  ← MACHINE

6m

- 1x 80mm coupling (540025)
- 1 x 6m x 84mm flexihose (570053)
- 2 x Hose clips 70mm - 90mm (580650)

## 120299

Diameter of Customers port or pipework	Hose Length	Purex Machine Inlet Diameter
80mm	3.0m	80mm

YOUR PROCESS ←  ← MACHINE

3.0m

- 1 x 80mm female coupling (540025)
- 1 x 3m x 82mm flexible hose (570053)
- 2 x 70-90mm hose clips (580650)

## 120258

Diameter of Customers port or pipework	Hose Length	Purex Machine Inlet Diameter
100mm	4.0m	80mm

YOUR PROCESS ←  ← MACHINE

4m

- 1x 100mm coupling (540120)
- 1 x Reducer 100mm - 80mm (540150)
- 2 x Hose clip 70mm - 90mm (580650)
- 1 x 4m x 84mm flexihose (570053)
- 1 x 80mm coupling (540025)

## 120326

Diameter of Customers port or pipework	Hose Length	Purex Machine Inlet Diameter
100mm	1.8	80mm

YOUR PROCESS →  ← MACHINE

0.3m

1.5m

← YOUR PROCESS

- 1x 80mm coupling (540025)
- 1x 100mm coupling (540120)
- 1x Equal tee 100 (540145)
- 1x Reducer 100mm - 80mm (540150)
- 1 x 1.5m x 80mm flexihose (570053)
- 2 x 2x 0.3m x 100mm flexihose (570060)
- 2x Hose clip 70mm - 90mm (580650)
- 4x Hose clip 90mm - 120mm (580660)

## 120297

Diameter of Customers port or pipework	Hose Length	Purex Machine Inlet Diameter
100mm	2m (Dual)	80mm

YOUR PROCESS ←  ← MACHINE

2.0m

- 3 x 80mm coupling (540025)
- 1 x 80mm equal tee (540070)
- 2 x 2m x 100mm flexible hose (421255)
- 4 x 90-120mm hose clips (580660)

Find out more: [W purex.co.uk](http://W purex.co.uk) | [T +44 \(0\)1405 746030](tel:+44(0)1405746030) | [E purex@purex.co.uk](mailto:purex@purex.co.uk)

Registered Office: Purex International LTD, Unit A, Saltgrounds Road, Brough, HU15 1EG, UK

Registered No. 5136616 England | VAT No. GB842 5025 49 | WEEE Producer Registration Number: WEE/CE0067TX

\*Goods are subject to change

# CONNECTION KITS

Please contact Purex for additional support

**PUREX**  
CLEAN AIR FOR EVERYONE

## 120328

Diameter of Customers port or pipework	Hose Length	Purex Machine Inlet Diameter
100mm	2.6m	80mm

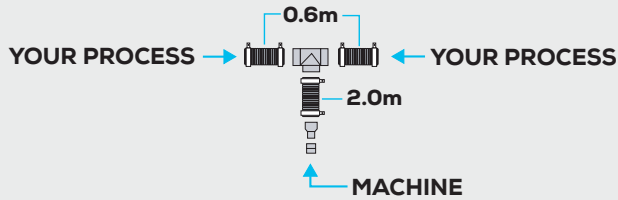

- 1x 80mm coupling (540025)
- 1x 100mm coupling (540120)
- 1x Equal tee 100mm (540145)
- 1x Reducer 100mm - 80mm (540150)
- 1 x 2x 0.6m & 1x 2m x 100mm flexihose (570060)
- 6x Hose clip 90mm - 120mm (580660)

## 120292

Diameter of Customers port or pipework	Hose Length	Purex Machine Inlet Diameter
100mm	1.3m	80mm

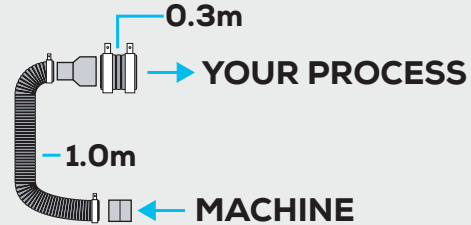

- 1 x 80mm female coupling (540025)
- 1 x 100mm to 80mm reducer (540150)
- 1 x 1m x 82mm flexible hose (570053)
- 2 x 70mm - 90mm hose clips (580650)
- 0.3m x 100mm flexible hose (570060)
- 2 x 90mm - 120mm hose clips (580660)

## 120288

Diameter of Customers port or pipework	Hose Length	Purex Machine Inlet Diameter
100mm	2.3m	80mm

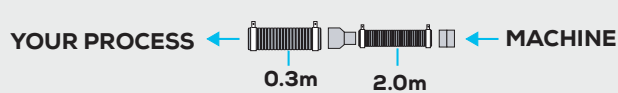

- 1 x 80mm female coupling (540025)
- 1 x 100mm to 80mm reducer (540150)
- 1 x 2m x 82mm flexible hose (570053)
- 1 x 0.3m x 100mm flexible hose (570060)
- 2 x 70-90mm hose clips (580650)
- 2 x 90-120mm hose clips (580660)

## 100171

Diameter of Customers port or pipework	Hose Length	Purex Machine Inlet Diameter
125mm	3.0m	80mm

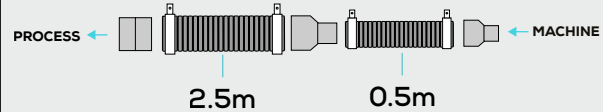

- 1 x 100mm to 80mm reducer (540150)
- 1 x 2.5m x 100mm flexible hose (570060)
- 1 x 125mm to 100mm reducer (540280)
- 1 x 125mm female coupling (540270)
- 2 x 70mm to 90mm hose clips (580650)
- 2 x 90mm to 120mm hose clips (580660)

## 120289

Diameter of Customers port or pipework	Hose Length	Purex Machine Inlet Diameter
150mm	3.3m	80mm

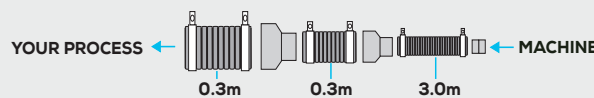

- 1 x 80mm female coupling (540025)
- 1 x 100mm - 80mm reducer (540150)
- 1 x 150mm - 100mm reducer (540382)
- 1 x 3m x 82mm flexible hose (570053)
- 1 x 0.6m x 150mm flexible hose (570070)
- 2 x 70 - 90mm hose clips (580650)
- 1 x 0.3 x 100mm flexible hose (570060)
- 2 x 90 - 120mm hose clips (580660)
- 2 x 135 - 160mm hose clips (580670)

Find out more: [W purex.co.uk](http://W purex.co.uk) | [T +44 \(0\)1405 746030](tel:+44(0)1405746030) | [E purex@purex.co.uk](mailto:purex@purex.co.uk)

Registered Office: Purex International LTD, Unit A, Saltgrounds Road, Brough, HU15 1EG, UK

Registered No. 5136616 England | VAT No. GB842 5025 49 | WEEE Producer Registration Number: WEE/CE0067TX

\*Goods are subject to change

# CONNECTION KITS

Please contact Purex for additional support

**PUREX**  
CLEAN AIR FOR EVERYONE

## 100mm Purex Inlet

### 100186

Diameter of Customers port or pipework	Hose Length	Purex Machine Inlet Diameter
100mm	1.0m	100mm

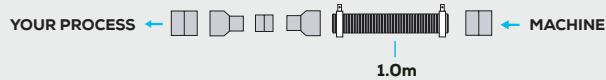

- 1 x 80mm coupling (540025)
- 2 x 100mm coupling (540120)
- 2 x Reducer 100mm - 80mm (540150)
- 1 x 1m 100mm flexihose (570060)
- 2 x Hose clip 90mm - 120mm (580660)

### 120291

Diameter of Customers port or pipework	Hose Length	Purex Machine Inlet Diameter
100mm	3m (Dual)	100mm

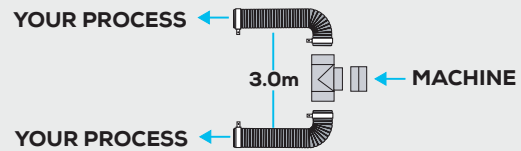

- 1 x 100mm female coupling (540120)
- 1 x 100mm equal tee (540145)
- 2 x 3m x 102mm flexible hose (570060)
- 4 x 90-120mm hose clips (580660)

### 120354

Diameter of Customers port or pipework	Hose Length	Purex Machine Inlet Diameter
100mm	0.5m	100mm

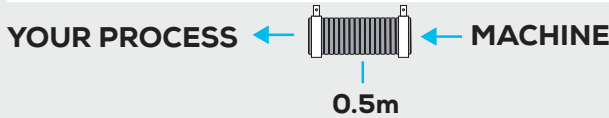

- 1 x 0.5m x 100mm flexihose (570060)
- 2 x Hose clip 90mm - 120mm (580660)

### 120270

Diameter of Customers port or pipework	Hose Length	Purex Machine Inlet Diameter
100mm	1.5m	100mm

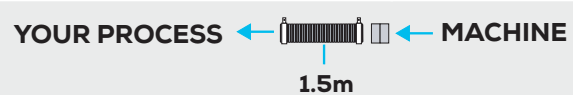

- 1 x 100 female coupling (540120)
- 1 x 1.5m x 100mm flexible hose (570060)
- 2 x 90mm to 120mm hose clips (580660)

### 120360

Diameter of Customers port or pipework	Hose Length	Purex Machine Inlet Diameter
100mm	1.0m	100mm

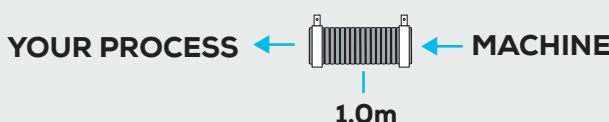

- 1 x 1m x 100mm flexihose (570060)
- 2 x Hose clip 90mm - 120mm (580660)

### 100186

Diameter of Customers port or pipework	Hose Length	Purex Machine Inlet Diameter
100mm	1.0m	100mm



- 1 x 80mm coupling (540025)
- 2 x 100mm coupling (540120)
- 2 x Reducer 100mm - 80mm (540150)
- 2 x 90-120mm hose clip (580660)
- 1 x 1m x 84mm flexihose (570053)

### 100107\*

Diameter of Customers port or pipework	Hose Length	Purex Machine Inlet Diameter
100mm	3.0m	100mm

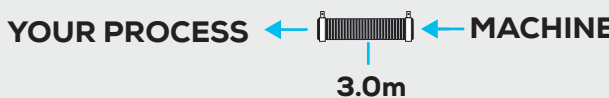

- 1 x 3m x 100mm flexible hose (570060)
- 2x 90mm to 120mm hose clips (580660)

\*Suitable for PVC applications

### 100184

Diameter of Customers port or pipework	Hose Length	Purex Machine Inlet Diameter
100mm	1.0m	100mm

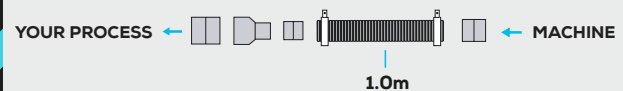

- 1 x 80mm coupling (540025)
- 1 x 100mm coupling (540120)
- 1 x Reducer 100mm - 80mm (540150)
- 2 x 70mm - 90mm hose clip (580650)
- 1 x 1m x 100mm flexihose (570060)

Find out more: [W purex.co.uk](http://W purex.co.uk) | [T +44 \(0\)1405 746030](tel:+44(0)1405746030) | [E purex@purex.co.uk](mailto:purex@purex.co.uk)

Registered Office: Purex International LTD, Unit A, Saltgrounds Road, Brough, HU15 1EG, UK

Registered No. 5136616 England | VAT No. GB842 5025 49 | WEEE Producer Registration Number: WEE/CE0067X

\*Goods are subject to change

# CONNECTION KITS

Please contact Purex for additional support

**PUREX**  
CLEAN AIR FOR EVERYONE

## 100172

Diameter of Customers port or pipework	Hose Length	Purex Machine Inlet Diameter
125mm	1.5m	100mm

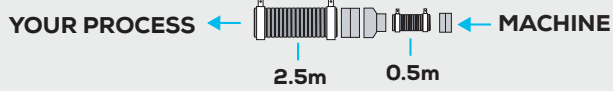

- 1 x Reducer 125mm to 100mm (540280)
- 1 x 2.5m x 125mm flexihose grey (570069)
- 2 x 135mm - 165mm hose clips (580670)
- 1 x 0.5m x 100mm flexihose (570060)
- 2 x 90mm - 120mm hose clip (580660)

## 120294

Diameter of Customers port or pipework	Hose Length	Purex Machine Inlet Diameter
150mm	3.25m	100mm

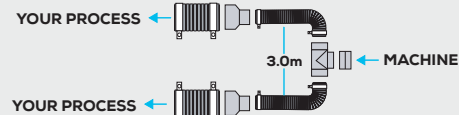

- 1 x 100mm female coupling (540120)
- 1 x 100mm equal tee (540145)
- 4 x 90 - 120mm hose clips (580660)
- 2 x 3m x 100mm flexible hose (570060)
- 2 x 150mm - 100mm reducer (540382)
- 2 x 0.25m x 150mm flexible hose (570070)
- 4 x 135 - 165mm hose clips (580670)

## 120320

Diameter of Customers port or pipework	Hose Length	Purex Machine Inlet Diameter
150mm	3.25m	100mm

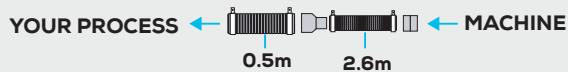

- 1x 100mm coupling (540120)
- 1x Reducer 150mm - 100mm (540382)
- 1x 100mm flexihose (570060)
- 1x 152mm flexihose
- 2x Hose clip 90mm - 120mm (580660)
- 2x Hose clip 135mm - 165mm (580670)

## 120340

Diameter of Customers port or pipework	Hose Length	Purex Machine Inlet Diameter
150mm	6.2m	100mm

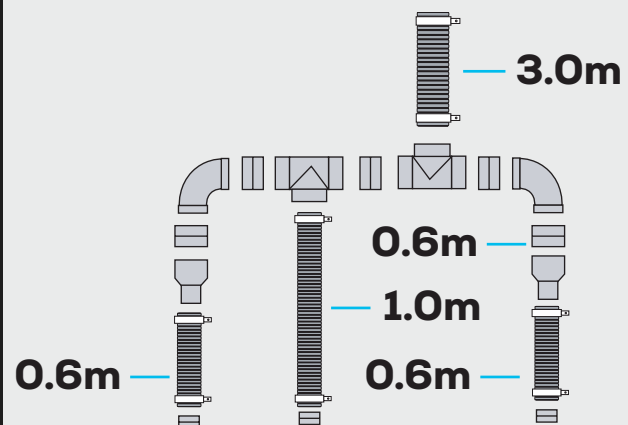

- 1 x Equal tee 150mm (540337)
- 5 x 150mm coupling (540320)
- 2 x 150mm 90° bend (540345)
- 1 x Equal tee 100mm (540336)
- 3 x 100mm coupling (540120)
- 1 x 3m x 152mm flexihose (570070)
- 1 x 3.2 100mm flexihose (570060)
- 6x Hose clip 90mm - 120mm (580660)
- 2x Hose clip 135mm - 165mm (580670)
- 2x Reducer 150mm - 100mm (540382)

## 125mm Purex Inlet

### 120300

Diameter of Customers port or pipework	Hose Length	Purex Machine Inlet Diameter
125mm	3m	125mm

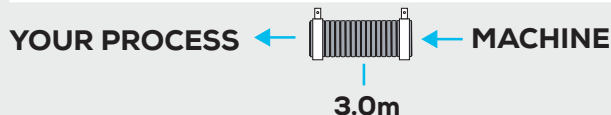

- 1 x 3m x 125mm flexible hose (570069)
- 2 x 125-165mm hose clips (580670)

Find out more: [W purex.co.uk](http://W purex.co.uk) | [T +44 \(0\)1405 746030](tel:+44(0)1405746030) | [E purex@purex.co.uk](mailto:purex@purex.co.uk)

Registered Office: Purex International LTD, Unit A, Saltgrounds Road, Brough, HU15 1EG, UK

Registered No. 5136616 England | VAT No. GB842 5025 49 | WEEE Producer Registration Number: WEE/CE0067X

\*Goods are subject to change



# CONNECTION KITS

Please contact Purex for additional support

**PUREX**  
CLEAN AIR FOR EVERYONE

## 150mm Purex Inlet

120287

Diameter of Customers port or pipework	Hose Length	Purex Machine Inlet Diameter
100mm	3m (Dual)	150mm

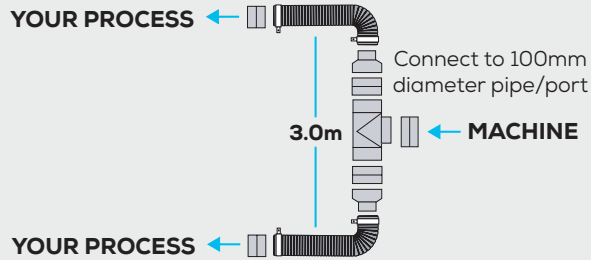

- ← YOUR PROCESS
- 2 x 100mm female coupling (540120)
  - 1 x 150mm equal tee (540337)
  - 2 x 150 to 100mm reducers (540382)
  - 2 x 3m x 102mm flexible hose (570060)
  - 4 x 90mm to 120mm hose clips (580660)
  - 3 x 150mm female couplings (540320)

120280

Diameter of Customers port or pipework	Hose Length	Purex Machine Inlet Diameter
150mm	1.5m	150mm

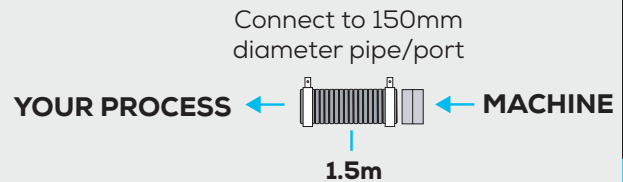

- 1 x 150mm female coupling (540320)
- 1 x 1.5m x 150mm flexible hose (570070)
- 2 x 135mm to 160mm hose clips (580670)

## 200mm Purex Inlet

120296

Diameter of Customers port or pipework	Hose Length	Purex Machine Inlet Diameter
200mm	1.0m	200mm

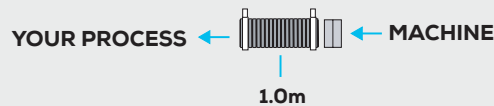

- 1 x 200mm female coupling (540701)
- 1 x 1m x 200mm flexible hose (570071)
- 4 x 90-120mm hose clips (580660)

Find out more: [W purex.co.uk](http://W purex.co.uk) | [T +44 \(0\)1405 746030](tel:+44201405746030) | [E purex@purex.co.uk](mailto:purex@purex.co.uk)

Registered Office: Purex International LTD, Unit A, Saltgrounds Road, Brough, HU15 1EG, UK

Registered No. 5136616 England | VAT No. GB842 5025 49 | WEEE Producer Registration Number: WEE/CE0067TX

\*Goods are subject to change

# SOLDERING KITS

Please contact Purex for additional support

**PUREX**  
CLEAN AIR FOR EVERYONE

100085

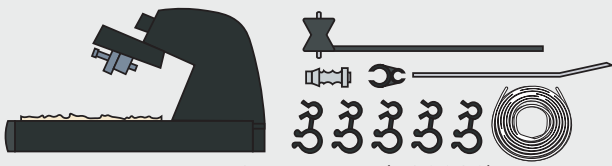

- 1 x 1.5m x Silicone wall (560030)
- 1 x Adaptor hose (580010)
- 5 x Swivel clip assembly (580525)
- 1 x Universal soldering iron stand (830007)
- 1 x Rubber clip universal solder tip (830051)
- 1 x Extraction tube (830135)

300001

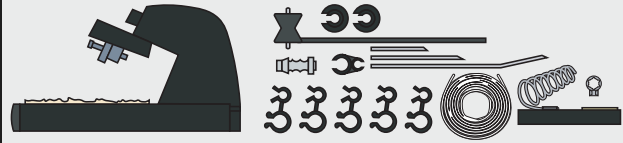

- 1 x 1.5m x Silicone wall (560030)
- 1 x Adaptor hose (580010)
- 5 x Swivel clip assembly (580525)
- 1 x Universal soldering iron stand (830007)
- 1 x Rubber clip universal solder tip (830051)
- 1 x Extraction tube (830135)
- 1 x Extraction tube - weller iron (830110)
- 1 x Extraction tube - metcal iron (830112)

300002

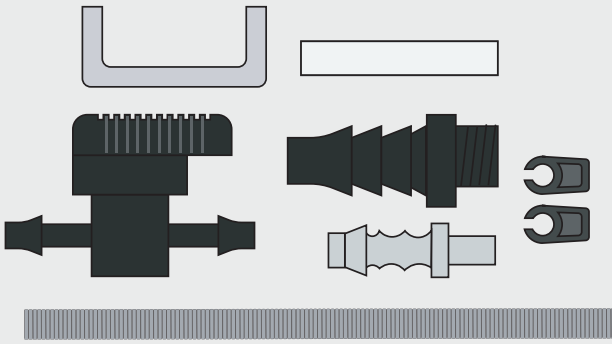

- 1 x 0.4m x Silicone wall (560030)
- 1 x 1m x 13mm hose - vsm grey (570000)
- 1 x Adaptor hose (580035)
- 1 x Bracket for ON/OFF tap (580090)
- 1 x Connector hose stem (580210)
- 2 x Hose clip 15mm (580500)
- 1 x ON/OFF tap black (590078)

300002

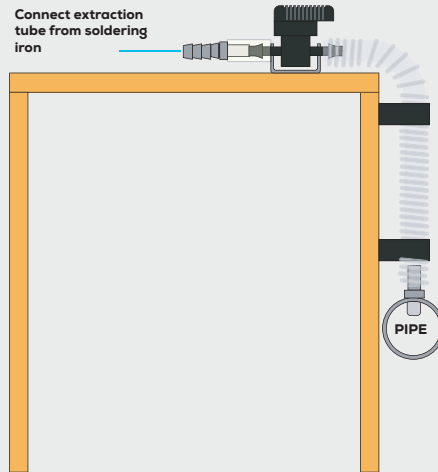

100100

**Connect extraction tube from soldering iron**

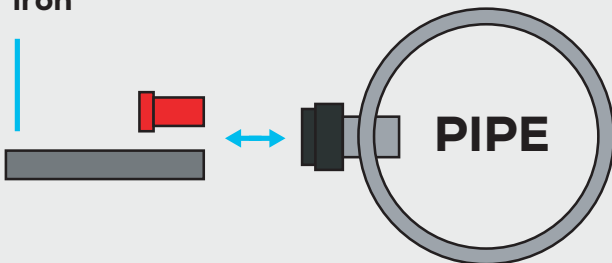

- 1 x Adaptor hose (580070)
- 1 x Blanked red plate (580130)
- 1 x Adaptor hose (580300)

100090

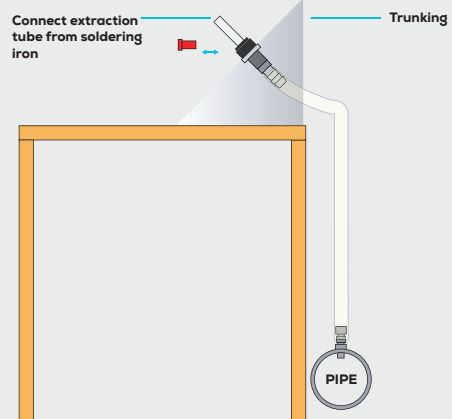

- 1 x 1.0m x Silicone wall (560030)
- 1 x Blanked red plate (580130)
- 1 x Connector Hose bulkhead (580190)
- 1 x Connect hose stem (580210)
- 1 x Adaptor hose (560030)
- 1 x Adaptor hose (580300)

Find out more: [W purex.co.uk](http://W purex.co.uk) | [T +44 \(0\)1405 746030](tel:+44(0)1405746030) | [E purex@purex.co.uk](mailto:purex@purex.co.uk)

Registered Office: Purex International LTD, Unit A, Saltgrounds Road, Brough, HU15 1EG, UK

Registered No. 5136616 England | VAT No. GB842 5025 49 | WEEE Producer Registration Number: WEE/CE0067TX

\*Goods are subject to change