

Analogue Series Operating Manual



Visit www.purex.co.uk for more information.

"The Future of Fume Extraction"

822006 | Rev 13

ATTENTION!

WARRANTY REGISTRATION

ATTENTION!

Machine details	
Model/Serial Number	
Purchased from	
Date of purchase	
Process	
Your details	
Title	
First name	
Surname	
Position	
Company	
Address 1	
Address 2	
Town/City	
Zip/Post code	
Telephone	
Fax	
Email	

**Important: To gain the maximum warranty period you must register your machine on installation.
See terms and conditions.**

Photocopy and post or fax to:

Purex International Ltd. QWP House, Island Drive, Capitol Park, Thorne, DN8 5UE, UK
T +44 (0)1405 746 030 F +44 (0)1405 746 047 W www.purex.co.uk E purex@purex.co.uk

Registered Office. Purex International Ltd. QWP House, Capitol Park, Thorne, Doncaster, DN8 5UE. Registered No. 5136616 England. VAT No. GB842 5025 49

Purex Inc, 2246 Palmer Drive, Unit 108, Schaumburg IL 60173, United States.
W: www.purexinc.com T: +1847 348 5203

CONTENTS

	Page
Warranty Registration	2
Consumables & Spares	3
Warnings	4
Routine Maintenance	4
Installing the Machine	5-6
Control System	7
Filtration & Changing Filters	8-10
Interfacing	11
Changing the Fuse	11
Troubleshooting	12
Terms & Conditions	13

ATTENTION!

CONSUMABLES & SPARES

ATTENTION!

Filters

Should always be ordered in advance of requirement from Purex or your authorised local agent.

Replacement filter part numbers are shown on the original packaging, please ensure you make a note here for future reference:

Pre-filter Part Numbers	
Main Filter Part Numbers	

Spare parts

When requesting spares please quote the model and serial number of your system. These details can be found on the

WARNINGS

The use of filters other than those supplied by Purex will invalidate any warranty, service contract and any LEV certification !

- Always isolate the system from the mains power supply before removing the machine cover.
- Disposable gloves and a dust mask are supplied with replacement filters/pre-filters. These should be worn when removing filters and disposed of with the used filter in the bag which is also provided.
- Filters are manufactured from non-toxic materials.
- Filters and pre-filters are not re-usable and no attempt should be made to clean them.
- Used filters and pre-filters should be disposed of in accordance with local laws and regulations. The company and its agents disclaim all liability and responsibility for any harm, damage, contamination or injury caused by inappropriate or unlawful disposal.
- Purex systems use high pressure pumps, which may cause inferior filters to burst, allowing hazardous fumes into the workplace. Do not use filters that have only been tested to BS3928, BS5295 or AS208C as these standards are flow checks only and are designed to test filters used in general dust extraction and air conditioning.
- Consult the local regulations concerning fume extraction systems, as these may be subject to requirements including: periodic checks by authorised agencies, re-issue of certificates of compliance or equivalents etc. Consult your supplier if in doubt.
- Consult your supplier for information on maintenance agreements that will ensure conformance to local regulations.



European Union (and EEA) only. (Applicable to FumeCube, FumeCube Lite, FumeSafe and FumeBuster only)
This symbol indicates that this product is not to be disposed of with your household waste, according to the WEEE Directive (2012/19/EU) and your national law. This product should be handed over to a designated collection point, e.g., on an authorized one-for-one basis when you buy a new similar product or to an

ROUTINE MAINTENANCE

Schedule

Primary maintenance is filter replacement, the machine control system will indicate when this is required (except FumeCube Lite). Filters should be replaced annually as a matter of course.

To ensure the smooth running of the extraction machine and associated equipment, please perform the following periodic checks:

- **Daily** - Visually check that the fumes are being drawn into the extraction point
- **Annual** - Change filters and consult your supplier for maintenance checks and/or certification

INSTALLING THE MACHINE

ENSURE ALL FILTERS ARE FITTED CORRECTLY PRIOR TO USING THE MACHINE

Positioning the machine

The machine should be as near to the process as possible with space allowed for the following access:

- Internal maintenance
- Control panel, replacing filters
- Exhaust air & cooling air, electrical connections, hose connection

Once in position, (if present) lock the two front castors by depressing the foot lever.

Hose connection

Incorrect connection or layout of hose can cause poor airflow, blockages and potentially dangerous build up of fume. Use the shortest length of hose possible and keep bends to a minimum. Your supplier can advise you of appropriate diameters and layouts of hose for your particular application.

- It is best practice to use the connection kit supplied.
- Do not reduce the diameter of the pipe / hose too much. The use of small diameter pipe / hose or nozzles can reduce the performance of fume extraction systems and so should be avoided.
- If a special connection kit or attachment is required please contact Purex or your local agent.

Ensure all connections are properly sealed and that there are no kinks in the hose. Once secured in position, connect

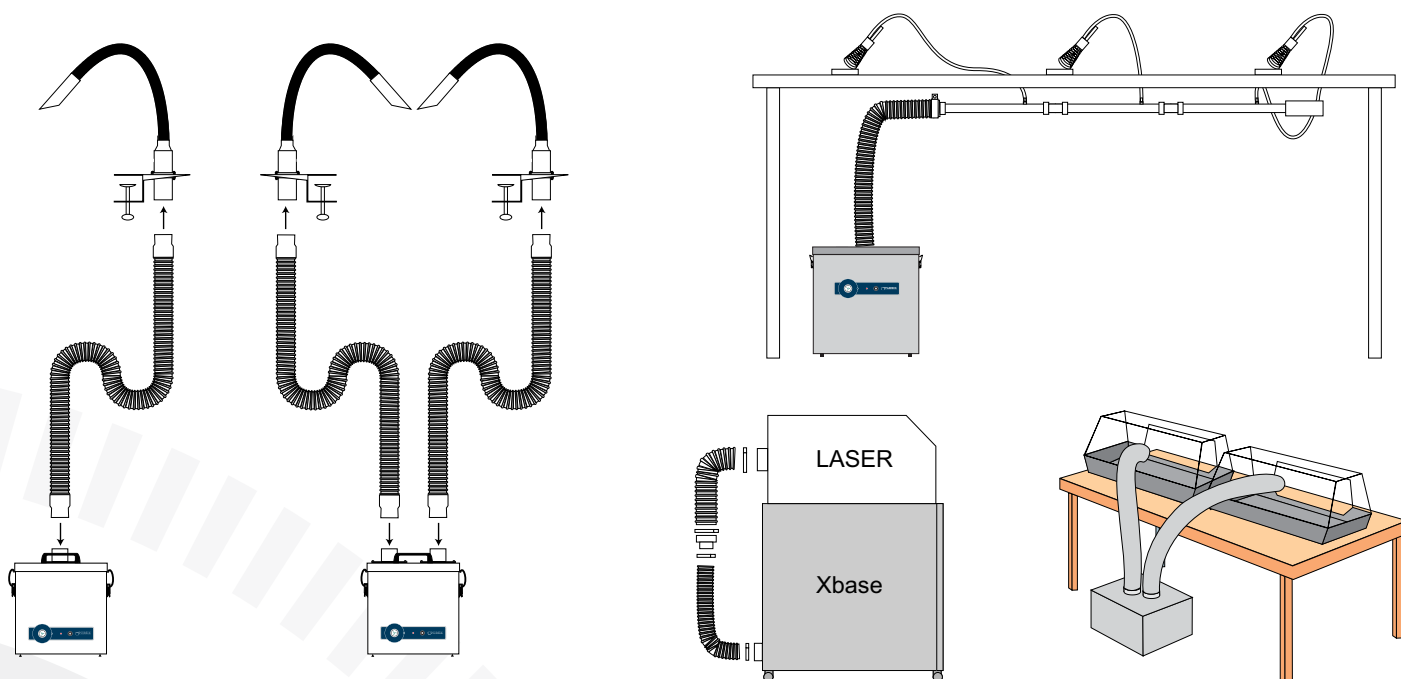

Examples of connection kits

Electrical connection

Prior to connecting the power supply, ensure that the voltage, frequency and power requirements are correct as shown on the label attached to the cabinet rear. Various connection methods are available to order. Ensure the plug is accessible as a disconnectable device.

INSTALLING THE MACHINE

PUR35

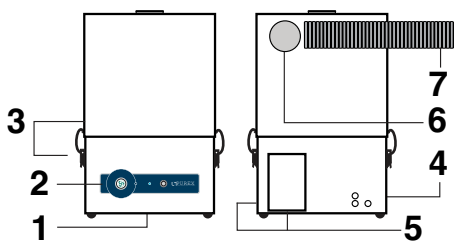

Ebase

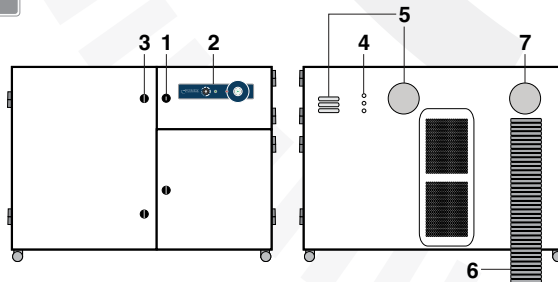

Alpha

Alpha
Dust

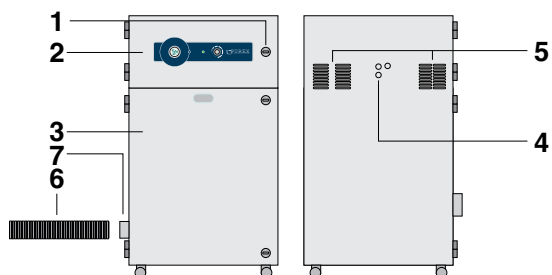

Xbase

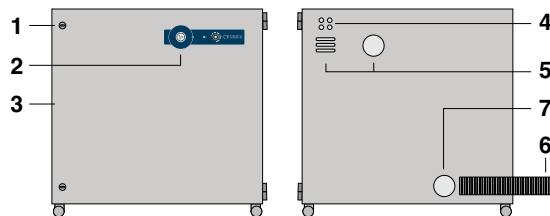

FumeCube

FumeCube
PRO

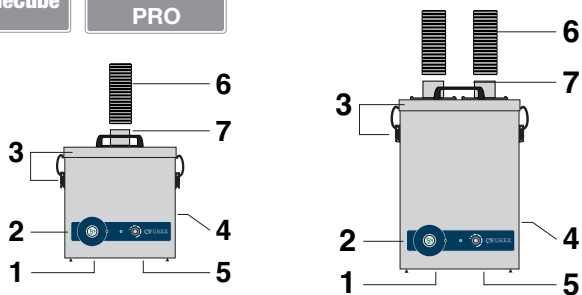

1 arm or 2 arm

FumeBuster

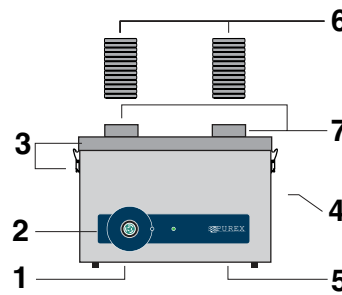

1 arm or 2 arm

FumeCube
Lite

2
Tip

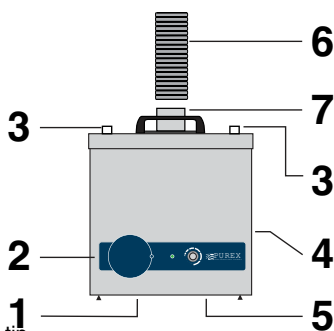

1 arm, 2 arm, 1 tip or 2 tip

FumeSafe

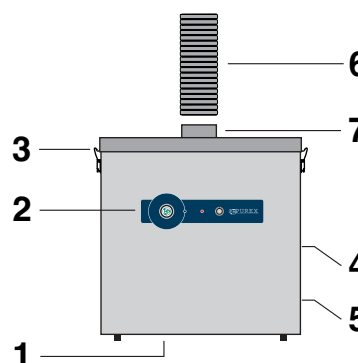

3-15 tip

FumeCube
MAX

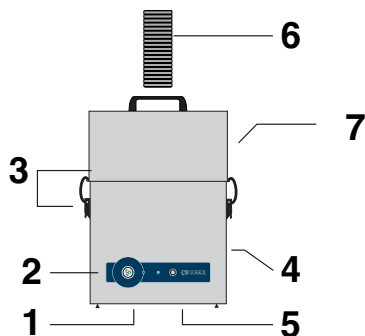

1 arm or 2 arm or with hose

LEGEND:

- 1. Access to internal components
- 2. Control panel
- 3. Access to replace filters
- 4. Electrical connections
- 5. Exhaust air + cooling air
- 6. Hose
- 7. Inlet

CONTROL SYSTEM

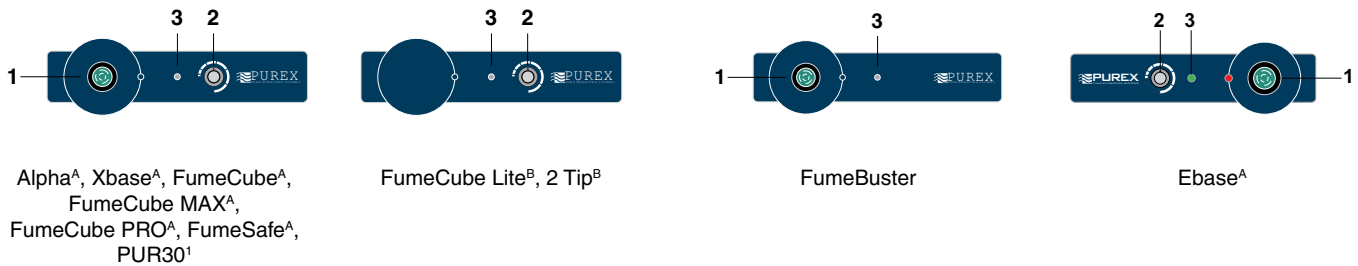

Set up

Ensure the fume extractor is connected to the correct electrical supply. Also ensure that the fume extractor is properly connected to the process before set up.

To switch the machine ON/OFF

- Alpha/Xbase/FumeCube/FumeCube MAX/FumeCube PRO/FumeBuster/FumeSafe/PUR30/Ebase - press button (1) which will illuminate green when ON.
- FumeCube Lite/2 Tip - turn the speed control knob (2) clockwise which will illuminate the green LED (3) when ON.

^A Fully Automatic Flow Control

The vacuum is the only parameter that needs to be set by the operator. The Purex machine will automatically maintain the vacuum level you have set without any further intervention required.

^B Speed Control

To increase the vacuum turn the speed control knob (2) clockwise. Turning the speed control knob anti-clockwise reduces the vacuum. There may be a slight delay as the speed control system raises or lowers the motor speed to match the required vacuum set by the user. The lowest vacuum level possible should be used so that the fume produced by the process is just drawn into the capture nozzle. Please note that setting the vacuum level unnecessarily high will reduce filter life.

Alarms

- Alpha/Xbase/FumeCube/FumeCube MAX/FumeCube PRO/FumeBuster/PUR30 - The control system actively monitors the airflow through the particle filters and shows the status via an LED.
 - Green illumination shows the filter is OK.
 - Amber illumination warns the operator that a replacement filter will be required (order now if none are available on site).
 - Red illumination (along with an audible alarm) tells the operator that the filter must be changed.
- FumeSafe/Ebase - The control system actively monitors the airflow through the particle filters and the LED illuminates red when new filters are required.
- FumeCube Lite/2 Tip - No filter monitoring

FILTRATION & CHANGING FILTERS

ENSURE ALL FILTERS ARE FITTED CORRECTLY PRIOR TO USING THE MACHINE. DO NOT LIFT THE FILTERS USING THE HANDLES, THESE ARE ONLY TO BE USED FOR SLIDING THE FILTERS OUT OF THE MACHINE (ALPHA, XBASE & EBASE MODELS ONLY). ENSURE THE AIRFLOW ARROW ON THE FILTER POINTS THE CORRECT WAY.

The machine employs a multi-stage filtration process. Contaminated air enters the machine from the process and is passed through a pre-filter which removes larger particles at approximately 1 micron in size and above. This prevents premature blockage of the main filter. The main HEPA filter removes 99.997% of particles larger than 0.3 microns in size and 95% of particles over 0.01 microns in size. The chemical filter section of the main filter removes toxic gases. The purified air is now returned to the workplace.

The contents of filters can vary depending on their application. For example some main filters do not contain HEPA media or the position of filter media may vary. Please ensure you have specified the correct filter for your application.

Important note:

Always check the following points for debris build up before changing any filter. This avoids false alerts related to airflow.

- Extraction nozzle
- Flexible hose and any pipework
- Air inlet

Changing filters

The machine will warn you if a particle filter is blocked (see control system - Except FumeCube Lite/2 Tip). Always wear the protective gloves and mask provided and dispose of with the used filters in the bag provided. Protective eyewear should also be worn when changing filters. Take care when removing main filters as they are heavy.

Opening the machine

It is important that the correct procedure below is followed when opening the machine. Failure to do so will result in your process operating without extraction which is an Occupational Health & Safety hazard.

- Ensure your process is stopped
- Switch off your Purex machine at the control panel (see control system)
- Turn the door locks on the front of the machine (Alpha, Xbase & Ebase)
- Release the catches on the lid (FumeCube, FumeCube MAX, FumeCube PRO, FumeSafe, FumeBuster & PUR30)
- Unscrew the thumb screws on the lid (FumeCube Lite, 2 Tip)
- Open the door or remove the lid

Important note:

Always check the extraction nozzle, flexible hose, any pipework and the air inlet for debris build up before changing any filter. This avoids false alerts related to airflow.

Always change the pre-filter first (unless recently changed) and restart the machine. If the alert continues, change the main filter.

Changing filters

Always wear the protective gloves and mask provided and dispose of with the used filters in the bag provided. Protective eyewear should also be worn when changing filters. Take care when removing main filters as they are heavy.

Changing the pre-filter

The pre-filter is situated in the compartment underneath the main filter in Alpha & Xbase models. In FumeCube, FumeCube Lite, FumeCube MAX, FumeCube PRO, FumeSafe, FumeBuster & PUR30 models the pre-filter is located above the main filter. In Ebase models the pre-filters are located in the left compartment.

Alpha, Alpha Dust, Xbase & Ebase models: -

- Open the door
- Pull the pre-filter (2) off the air inlet (1) and remove
- Insert the new filter, pushing the hole in the filter over the air inlet (1)
- Close and lock the door and restart the machine

FumeCube, FumeCube Lite, 2 Tip, FumeSafe, FumeBuster & PUR30 models: -

- Remove the lid
- Remove the old pre-filter and replace it with the new one. If the pre-filter is a pad, make sure the harder, smoother side is facing the filter. On FumeSafe machines ensure the yellow side of the filter faces up. On PUR30 models ensure the handles are to the top.
- Replace the lid, secure the catches (or screws) and restart the machine

FumeCube MAX & FumeCube PRO models: -

- Remove the lid
- Pull the filter (2) off the air inlet (1) and remove
- Insert the new filter, pushing the hole in the filter over the air inlet (1)
- Replace the lid, secure the catches or screws and restart the machine

Changing the main filter

Alpha, Xbase & Ebase models: -

- Open the door
- Turn the filter locking handle (6) 180° anti-clockwise so that it is horizontal and in the filter unlocked position
- The filter (3) should drop slightly to allow release
- Remove the filter by sliding it towards you and remove it completely from the machine (do not use the handles to carry the filter)
- Insert the new filter completely into the machine ensuring that the airflow arrow on the label (7) is pointing up. (Purex recommend the pre-filter is also changed unless you know it has been already changed recently)
- Turn the filter locking handle 180° clockwise so that it is horizontal and in the filter locked position
- Close and lock the door and restart the machine

FumeCube, FumeCube MAX, FumeCube PRO, 2 Tip, FumeCube Lite, FumeSafe, FumeBuster & PUR30 models: -

- Remove the lid and lift the filter out of the machine
- Insert the new filter completely into the machine ensuring that the airflow arrow on the label (7) is pointing down. (Purex recommend the pre-filter is also changed unless you know it has been already changed recently)
- Replace the lid, secure the catches or screws and restart the machine

FILTRATION & CHANGING FILTERS

LEGEND:

- 1) Air inlet.
- 2) Pre-filter.
- 3) Main Filter (HEPA location). †
- 4) Main Filter (Carbon location). †
- 5) Clean air returned to workplace.

- 6) Filter locking handle.
- 7) Filter identification label with airflow direction

Alpha, Xbase, FumeCube PRO, PUR30 and Ebase machines are mounted on four castors for increased mobility.

† Standard filter only. Filter contents can vary.

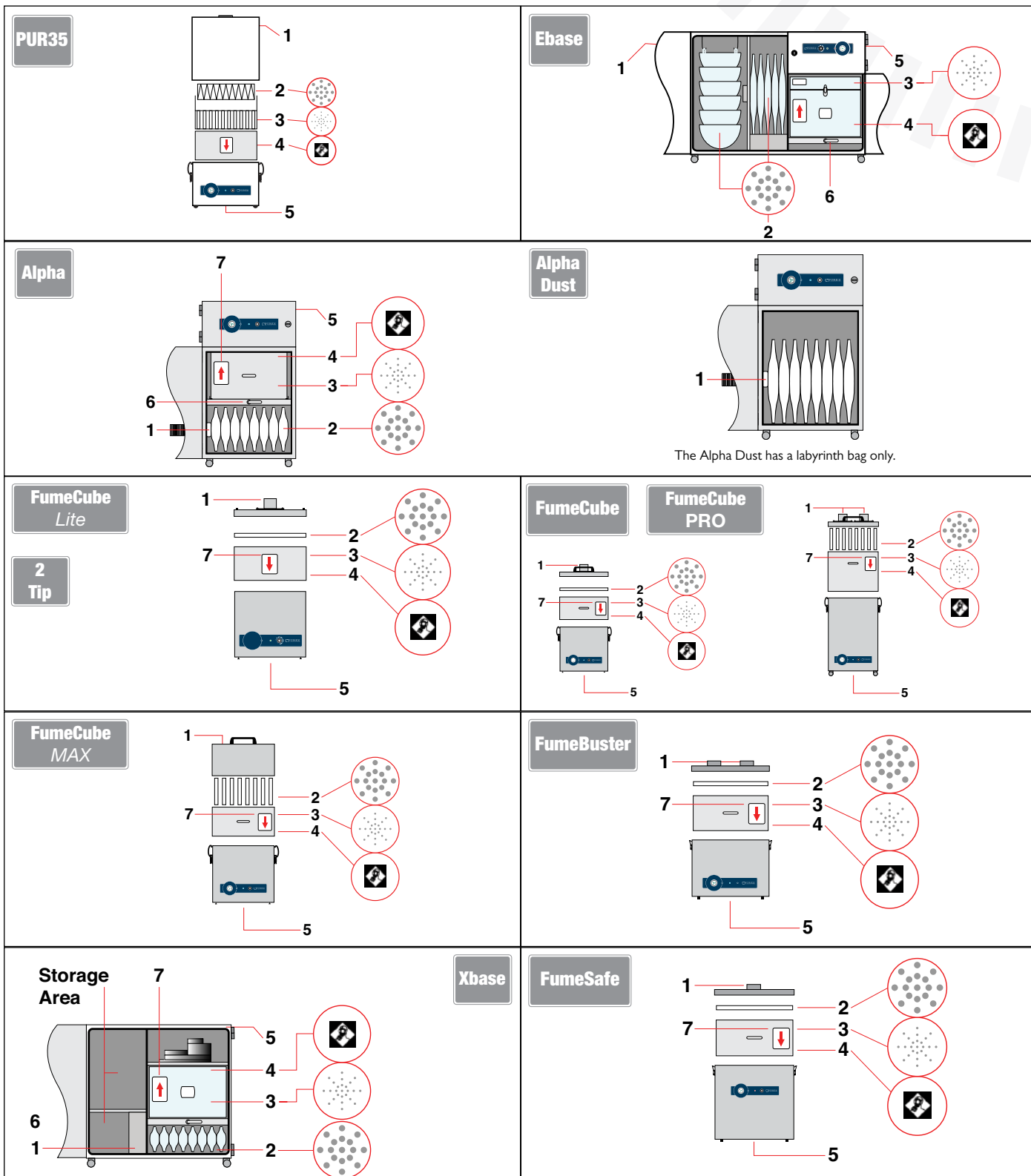
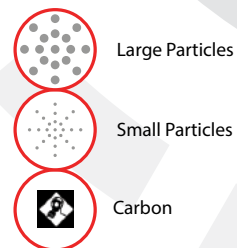

INTERFACING

PUR30, Ebase, Alpha , FumeCube, FumeCube PRO, FumeCube MAX & Xbase only

Interface Socket (1) (where fitted)

When not in use this socket is protected by a screw-on cap and the interface switch **MUST be set to '0'** otherwise the fume extractor will not work.

Interface Switch (2)

To enable interfacing move the **switch to the '1' position**, unscrew the interface socket cap and plug in the interface cable or remote ON/OFF switch. Then connect the other end of the interface cable to your related machine or use the remote ON/OFF switch depending on which you have purchased. Please note there is only one interface socket so an interface cable and the remote ON/OFF switch cannot be used together.

Power Socket (3)

Connect the power cable provided to this socket.

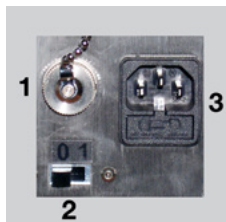

The interfacing socket, switch and power socket.



An interfacing cable

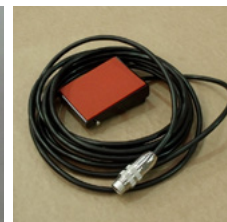

Remote ON/OFF switch (5m)

CHANGING THE FUSE

If a fuse has to be replaced it is important that this procedure is followed to ensure safe and efficient operation of the Purex unit:

Round Cap

- Ensure the machine is isolated from the mains power supply.
- Remove the blown fuse by unscrewing the fuse holder cap (using a suitable screwdriver) in an anti-clockwise direction and withdraw the spent fuse.
- Check the fuse holder, if there are any signs of damage contact Purex technical support, if there is no obvious damage continue as follows.
- Fit a replacement fuse, ensuring the type and fuse rating is correct; if in any doubt contact Purex technical support.
- Re-fit the cap to the machine by applying gentle pressure and rotating it in an anti-clockwise direction until the cap is felt to click.
- Using a correctly sized screwdriver, turn the fuse holder cap 1¼ full turns (450 degrees) in a clockwise direction.
- If the above procedure is not effective, contact Purex technical support.

Rectangular Cap

- Ensure the machine is isolated from the mains power supply.
- Remove the blown fuse by prising open the fuse cover which is part of the power socket.
- Check the fuse holder, if there are any signs of damage contact Purex technical support, if there is no obvious damage continue as follows.
- Fit a replacement fuse, ensuring the type and fuse rating is correct. If in any doubt contact Purex technical support.
- Close the fuse cover.
- If the fuse holder shows any physical damage or the above procedure is not effective, contact Purex technical support.

TROUBLESHOOTING

Amber LED ON (Alpha, Xbase, FumeCube, FumeCube MAX, FumeCube PRO, FumeBuster & PUR30 only)	
The pre-filter and/or main filter may be blocking.	One or both of these filters may be reaching the end of their useful life, you should ensure replacement filters are available. If these filters have been recently changed then another fault may be causing the LED to illuminate. See below.
Red LED ON (Except 2 Tip, FumeCube Lite)	
The pre-filter and/or main filter may be blocked.	One or both of these filters may be blocked. Unless recently changed you should first replace the pre-filter and re-start the machine. If the red LED (or audible alarm) does not switch off you should then replace the main filter. If these filters have been recently changed then another fault may be causing the LED to illuminate. See below.
If the filter blocked alarm continues after filters have been certified as OK then see below...	
Connecting hose may have a leak or the vacuum sensor tubes in the air inlet of Xbase and Alpha models may be blocked.	Check all hose, seals and connections for leaks and check the vacuum sensor tube for blockage.
The alarm has triggered and the blower stops.	The thermal cutout on the blower may have engaged. Check the cooling vents both inside and out. Switch off mains power and allow the blower to cool. If this does not remedy the fault please contact your supplier.
Electrical faults	
Blower does not function or has developed a fault.	Procedure: <ul style="list-style-type: none"> Check all cables and connections inside and out. Ensure the power supply matches the requirements of the machine. Check any fuses outside the machine. Switch off main power, check all vents for blockages, allow motor to cool and restart. An electrical part may need replacement, contact supplier.
Control signal to/from interfaced equipment is incorrect or absent.	
The control PCB inside the machine does not function or has developed a fault.	
LED is not illuminated.	
Filter Faults	
Odour or particles in exhaust air.	The main filter may be damaged, fitted incorrectly or missing or the chemical section of the main filter may be exhausted. Check main filter and replace if necessary.
Airflow insufficient to remove fume when the filter is not blocked.	Possible airflow leak or a blockage. Check all hose, seals and connections for leaks and check the vacuum sensor tube for blockage. If OK then increase airflow level (speed control models
The main filter has a shorter than expected life.	Large particles may be bypassing the particle pre-filter. Check the particle pre-filter which may be damaged or missing.

TERMS & CONDITIONS

1. Contract

1.1 All quotations given, orders accepted and contracts entered into by Purex International Limited ("Purex") with any person ("Purchaser") for supply of goods ("Goods"), or for services ("Services") are subject to these conditions of sale ("Conditions"). All other terms and conditions, whether expressly stipulated by the Purchaser or implied by trade custom, course of dealing or otherwise are excluded. No variation to these Conditions will be effective unless agreed in writing by an authorised representative of Purex.

1.2 No quotation, estimate or proposal issued by Purex is an offer that is capable of acceptance by the Purchaser. Any order issued by the Purchaser shall be deemed placed subject to these Conditions and shall constitute an offer that Purex may accept or reject. The contract between Purex and the Purchaser ("Contract") shall be formed at the time Purex accepts the Purchaser's order. Purex may accept the Purchaser's order by issuing an order acknowledgement or by other means, including commencing the supply of Goods or the performance of Services. No amendments to the Purchaser's order shall be valid unless agreed in writing by an authorised representative of Purex.

2. Order and Specifications

The Purchaser shall be responsible to Purex for ensuring the accuracy of the terms of any order, including any applicable specification, submitted by the Purchaser, and for giving to Purex any necessary information relating to the Goods or Services within a sufficient time to enable Purex to perform the Contract in accordance with its terms. The specification for the Goods or Services shall be that set out in the Purchaser's order or as otherwise agreed in writing by Purex. Should an order be cancelled by the Purchaser within 2 months of the relevant delivery date Purex reserves the right to impose a reasonable cancellation charge.

3. Price and Payment

3.1 The price of Goods and Services shall be the price quoted by Purex. Quoted prices shall remain valid for 30 days. Prices do not include carriage and packing which will be charged at cost plus a handling fee unless otherwise specified in writing. Express or Special Delivery at the Purchaser's request will always be at the Purchaser's expense. Prices do not include VAT.

3.2 Unless otherwise agreed in writing payment of invoices shall be made in full without any deduction or set-off within 30 days of the invoice date. Payment shall be due whether or not property in the Goods has passed. Time for payment shall be of the essence. If the Purchaser fails to pay Purex any sum due pursuant to the Contract, the Purchaser shall be liable to pay interest to Purex on such sum from the due date for payment at the annual rate of 4% above the base lending rate from time to time of The Bank of England, accruing on a daily basis until payment is made, whether before or after any judgement. Purex reserves the right to claim interest under the Late Payment of Commercial Debts (Interest) Act 1998. Purex may also, without prejudice to any other remedy suspend or cancel further supply of Goods or performance of Services whether under this or any other Contract until the Purchaser makes payment in full together with any applicable interest.

4. Delivery

4.1 Delivery of the Goods shall unless otherwise agreed be made by Purex delivering the Goods to the location specified in the Purchaser's order or by the Purchaser collecting the Goods at Purex's premises.

4.2 Any dates or times for delivery of Goods and performance of the Services are approximate only. Purex shall use reasonable endeavours to meet such dates or times but so long as it uses such reasonable endeavours Purex shall not be liable to the Purchaser, in contract, tort, negligence or otherwise for any loss or damage whatsoever resulting from any late delivery or performance.

4.3 Where the Goods are delivered by instalments, any breach by Purex in respect of any one or more instalments shall not entitle the Purchaser to terminate the Contract in whole or in part.

4.4 Upon receipt of the Goods the Purchaser shall examine them and shall within 48 hours of such receipt give notice in writing to Purex of any apparent defects and/or shortages. The parties will agree between themselves such further action as may be necessary to remedy the defect and/or shortage. Purex shall not be liable for any such defects and/or shortages notified to it after the period of 48 hours after receipt.

5. Risk and Title

5.1 Risk of damage to or loss of the Goods shall pass to the Purchaser when Purex delivers the Goods to the Purchaser or, if the Purchaser collects the Goods from Purex, when the Goods are loaded onto transport at Purex's premises.

5.2 Notwithstanding the passing of the risk, Purex shall retain title to and ownership of the Goods until it has received payment in full of all sums due for the Goods.

5.3 Until title in the Goods has passed to the Purchaser, the Purchaser shall be in possession of them as a bailee of the Goods for Purex and shall store the Goods, properly insured and protected, separately from any Goods belonging to the Purchaser or any third party and shall be clearly marked and identifiable as being Purex's property. Purex shall be entitled to enter the Purchaser's premises upon reasonable notice to verify the Purchaser's compliance with this clause. If the Purchaser fails to make any payments to Purex when due, or any of the circumstances set out in Clause 8.2 arise, then Purex will have the right, without prejudice to any other remedies:

5.3.1 to enter, without prior notice, any premises where Goods owned by Purex may be, and to repossess and dispose of any such Goods; and/or

5.3.2 to require the Purchaser not to resell or part with possession of any Goods owned by Purex until the Purchaser has paid in full all sums due to Purex under this or any other Contract.

5.4 The Purchaser shall not be entitled to pledge or in any way charge by way of security for any indebtedness any of the Goods which remain the property of Purex and if the Purchaser does so all monies owing by the Purchaser to Purex shall (without prejudice to any other right or remedy of Purex) forthwith become due and payable.

6. Warranty & Liability

6.1 Goods manufactured by Purex : Purex warrants that the Goods manufactured by it will be free from defects in materials and workmanship for a period of 12 months from the date of installation or 15 months from the date of despatch from Purex's premises, whichever period expires earlier. Exceptions :

Spare parts including replacement filters : 3 months from installation or 4 months from despatch

Used and ex-demonstration equipment: 3 months from installation or 4 months from despatch

In the case of any breach of warranty then Purex shall at its option remedy such defects or refund such sums as the Purchaser has paid to Purex in respect of such Goods. Purex shall be under no liability under the above warranties:

6.1.1 arising from any drawing, design or specification supplied by the Purchaser;

6.1.2 arising from improper installation, storage, use, modification or operation including but not limited to the use of consumable items not approved by Purex;

6.2 Goods manufactured by third parties : Purex will use its best endeavours to obtain for the purchaser the benefit of any warranty provided by the original manufacturer of the Goods. Repair or replacement, in whole or in part, of Goods which fail due to faulty manufacture is available from the original manufacturer under its warranty. Purex must be consulted to approve the return of Goods for replacement or repair under the original manufacturer's warranty.

6.3 All replacement items will be charged at the point of despatch. Provided the original items are received back at Purex within 28 days from the date upon which the Returns Authorisation Number is issued and Purex agree following testing / inspection that these are defective, a credit note will be issued.

6.4 Services : Purex warrants that it will carry out the Services with reasonable care and skill. If Purex is shown to be in breach of this warranty in respect of particular Services it shall at its option and cost either re-provide those Services or refund any sums already paid in respect of those Services.

6.5 Purex does not exclude or limit its liability in negligence for death or personal injury, or for fraud or wilful default, or otherwise to the extent that any exclusion or limitation of its liability is void, prohibited or unenforceable by law.

6.6 Subject to Clauses 6.1 - 6.5, all representations, warranties and conditions implied by trade custom, course of dealing, statute, common law or otherwise are excluded to the fullest extent permitted by law.

6.7 Subject to Clause 6.5, in no circumstances shall Purex be liable to the Purchaser, in contract, tort, negligence or otherwise, for any incidental or consequential loss including, without limitation, any loss of profit, business, revenue, goodwill or anticipated savings or for any special, exemplary or consequential damages or other financial loss whatsoever arising out of or in connection with the Contract or the supply of the Goods or Services or their use or resale (if applicable) by the Purchaser.

6.8 If notwithstanding the provisions of these Conditions Purex is found liable for any loss suffered by the Purchaser arising in any way out of or in connection with the Contract or the supply of any Goods or Services, that liability shall in no event exceed the price paid for such Goods or Services.

6.9 The parties hereby confirm that notwithstanding any other provision of the Contract or these Conditions, the Contract shall not and shall not purport to confer on any third party the right to enforce any term of the Contract for the purposes of the Contracts (Rights of Third Parties) Act 1999.

6.10 Purex and third party Software

6.10.1 Software is licensed (or sublicensed, in case of third party Software) by Purex to the Purchaser.

6.10.2 Purex warrants that the media on which the Software is recorded is free from defects in material and workmanship under normal use for a period of thirty days from the date of despatch.

6.10.3 Purex warrants that any Purex Software will perform in substantial compliance with the specification for a period of 90 days from installation.

6.10.4 Purex warrants that any third party Software will perform in substantial compliance with the Software documentation issued by the original manufacturer of the Software and for the period specified therein.

6.10.5 Purex (and, where applicable, the original manufacturer of the Software) do not warrant that the functions contained in the Software will meet Purchaser's requirements or operate in the combination that may be selected for use by Purchaser, that the operation of the Software will be uninterrupted or error-free or that all defects in the Software will be corrected.

6.10.6 The entire liability of Purex (and, where applicable, of the original manufacturer of the Software) shall be, at Purex's option, either :

(a) Return of all sums paid by the Purchaser for the Software, or

(b) Replacement of the Software or media that does not meet Purex or the original manufacturer limited warranty and which is returned to Purex under its return policy.

6.10.7 Any replacement Software or media will be warranted for the remainder of the original warranty period or 30 days, whichever is longer.

7. Force Majeure

Purex shall not be deemed in breach of the Contract or otherwise liable to the Purchaser, by reason of any delay in performance, or non-performance of its obligations under the Contract to the extent that such delay or non-performance is caused by an event or circumstance beyond Purex's reasonable control. In such events Purex may, without liability to the Customer, reasonably vary the terms of the Contract including but not limited to extending the time for performing the contract by a period of at least equal to the time lost due to such an event.

8. Termination

8.1 Purex may at any time by notice in writing to the Purchaser terminate the Contract with effect from the date of service of such notice if:

8.1.1 The Purchaser commits a material breach of the Contract and fails to remedy such breach within 14 days after Purex has given written notice to the Purchaser identifying the breach and requiring it to be remedied; or

8.1.2 The Purchaser is unable to pay its debts as they fall due within the meaning of Section 123 of the Insolvency Act 1986 or if any petition is presented for the appointment of an administrator or receiver or trustee in bankruptcy in respect of the Purchaser or any part of its undertaking or assets or an administrative receiver is appointed in respect of any of the Purchaser's undertaking or assets or if the Purchaser makes or attempts to make any arrangement with or for the benefit of its creditors or if the Purchaser ceases or threatens to cease to carry on business.

9. Miscellaneous

9.1 The expressions "in writing" and "written" include fax transmission. Purex shall be entitled to sub-contract any or all of its obligations under the Contract and to assign the Contract and the Customer shall at Purex's cost do all such things as may be necessary to enable Purex to so assign the Contract. Any failure or neglect by Purex to enforce at any time any provision of the Contract shall not be construed nor deemed to be a waiver of any of Purex's rights under the Contract. The Contract shall be governed by and construed in accordance with English law and the parties hereby submit to the exclusive jurisdiction of the English courts in relation to any claim or controversy arising out of or connected with the Contract.

9.2 New Accounts : Credit accounts cannot be opened under the minimum amount in operation at the time of placing the order. Customer's wishing to open a credit account must furnish two trade references and a Bank reference.

9.3 Specification Alterations : Purex reserves the right to alter the specification of any goods without prior reference to the Purchaser provided that the goods comply in all other known respects with the Purchaser's requirements.

9.4 Trade-Marks / Patents : The supply of goods by Purex shall not confer any right upon the Purchaser to use any Purex trade-mark without prior written consent of Purex and at all times such trade-mark shall remain the property of Purex. Neither does it imply any right to use any Purex patent or any indemnity against infringement of third party patents.

9.5 Catalogues : Catalogues and other advertising matter are issued to indicate the type and range of goods we offer and no particulars therein are binding to Purex.



THIS PAGE HAS BEEN LEFT INTENTIONALLY BLANK

THIS PAGE HAS BEEN LEFT INTENTIONALLY BLANK



Purex International Ltd.

QWP House
Island Drive, Capitol Park
Thorne, South Yorkshire
DN8 5UE, UK

T: +44 (0)1405 746 030

F: +44 (0)1405 746 047

E: purex@purex.co.uk

W: www.purex.co.uk

Purex Incorporated

2246 Palmer Drive
Unit 108, Schaumburg
Illinois 60173
United States

T: +1847 348 5203

E: sales@purexinc.com

W: www.purexinc.com